

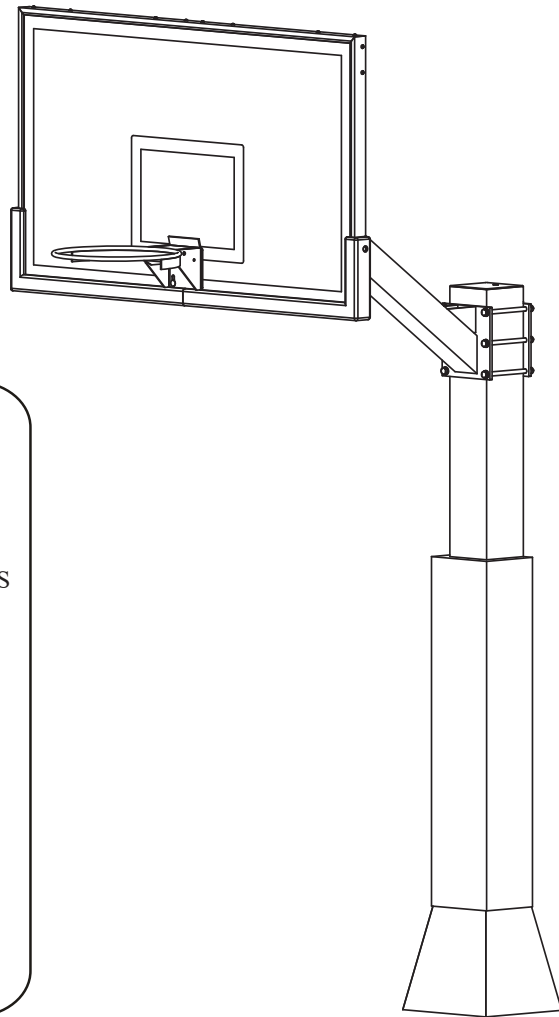

## FIXED HEIGHT BASKETBALL SYSTEM ASSEMBLY INSTRUCTIONS

**F/5™ FIXED  
SERIES**



**WARNING**



FAILURE TO COMPLY WITH ANY OF THE WARNINGS IN THESE INSTRUCTIONS MAY RESULT IN SERIOUS PERSONAL INJURY.

FAILURE TO COMPLY MAY ALSO RESULT IN PROPERTY DAMAGE. PLEASE HEED ALL WARNINGS AND CAUTIONS TO ENSURE YOUR SAFETY.

DO NOT ATTEMPT TO ASSEMBLE THIS SYSTEM WITHOUT CAREFULLY READING AND FOLLOWING ALL INSTRUCTIONS. BEGIN BY IDENTIFYING AND TAKING INVENTORY OF ALL PARTS USING THE PARTS LIST PROVIDED.

Douglas Industries, Inc.  
3441 South 11th Ave.-Eldridge, IA 52748  
Telephone: 1-800-553-8907  
[www.douglas-sports.com](http://www.douglas-sports.com)

Keep this instruction manual in case you have to contact the manufacturer for replacement parts.

**TOOLS AND MATERIALS REQUIRED FOR ASSEMBLY  
(Not Included)**

- |                            |   |
|----------------------------|---|
| 1. (2) Adjustable Wrenches | 10. Concrete-1/2 yard or 14-16<br>Bags, (80 lb. bags) |
| 2. Socket Set              | 11. Phillips Head Screwdriver                         |
| 3. 9/16" Wrench            | 12. A minimum of 2 Ladders                            |
| 4. 3/4" Wrench             | 13. Carpenter's Level                                 |
| 5. 15/16" Wrench           | 14. Water Supply                                      |
| 6. 1/2" Wrench             |   |
| 7. Hammer or Mallet        |   |
| 8. Tape Measure            |   |
| 9. Shovel                  |   |

**\*\*A MINIMUM OF 3 - 4 ADULTS IS  
REQUIRED TO LIFT UNIT INTO PLACE\*\***

**STOP!**

**BEFORE YOU START**

**STOP!**

- A. Identify and inventory all parts using the checklist boxes in the parts list. Be sure to keep the hardware bags and their contents separate. If any parts are missing call our Customer Service Department (800-553-8907).
- B. Test fit all Bolts by inserting them into the respective hole. If necessary, carefully scrape away any excess powder coating buildup from inside the holes. Do not scrape away all of the powder coating. Bare metal may rust.



**SAFETY INSTRUCTIONS**



FAILURE TO FOLLOW THESE SAFETY INSTRUCTIONS MAY RESULT IN SERIOUS INJURY OR PROPERTY DAMAGE AND WILL VOID THE WARRANTY. The owner must ensure that all players know and follow these rules to safely operate the system. Proper and complete assembly, use and supervision is essential for proper operation and to reduce the risk of accident or injury. A high probability of serious injury exists if this system is not installed, maintained, or operated properly.

- If using a ladder during assembly, use extreme caution. Follow all warnings and cautions on the ladder carefully.
- 6 people are required to lift the unit into place.
- Before digging, contact the appropriate agency to locate underground power cables, gas, and water lines. Do not install the system within 20 feet of overhead power lines.
- Climate, corrosion, or misuse could result in system failure.
- If technical assistance is required, contact the manufacturer.
- Minimum operational height is 7'6" to the Rim. Most injuries are caused by misuse and/or failure to follow instructions. Use caution when using the system.

# PARTS LIST

Verify all parts listed on packing list are present prior to installation.

Contact our Customer Service at 1-800-553-8907 for assistance with replacement of any parts missing or damaged.

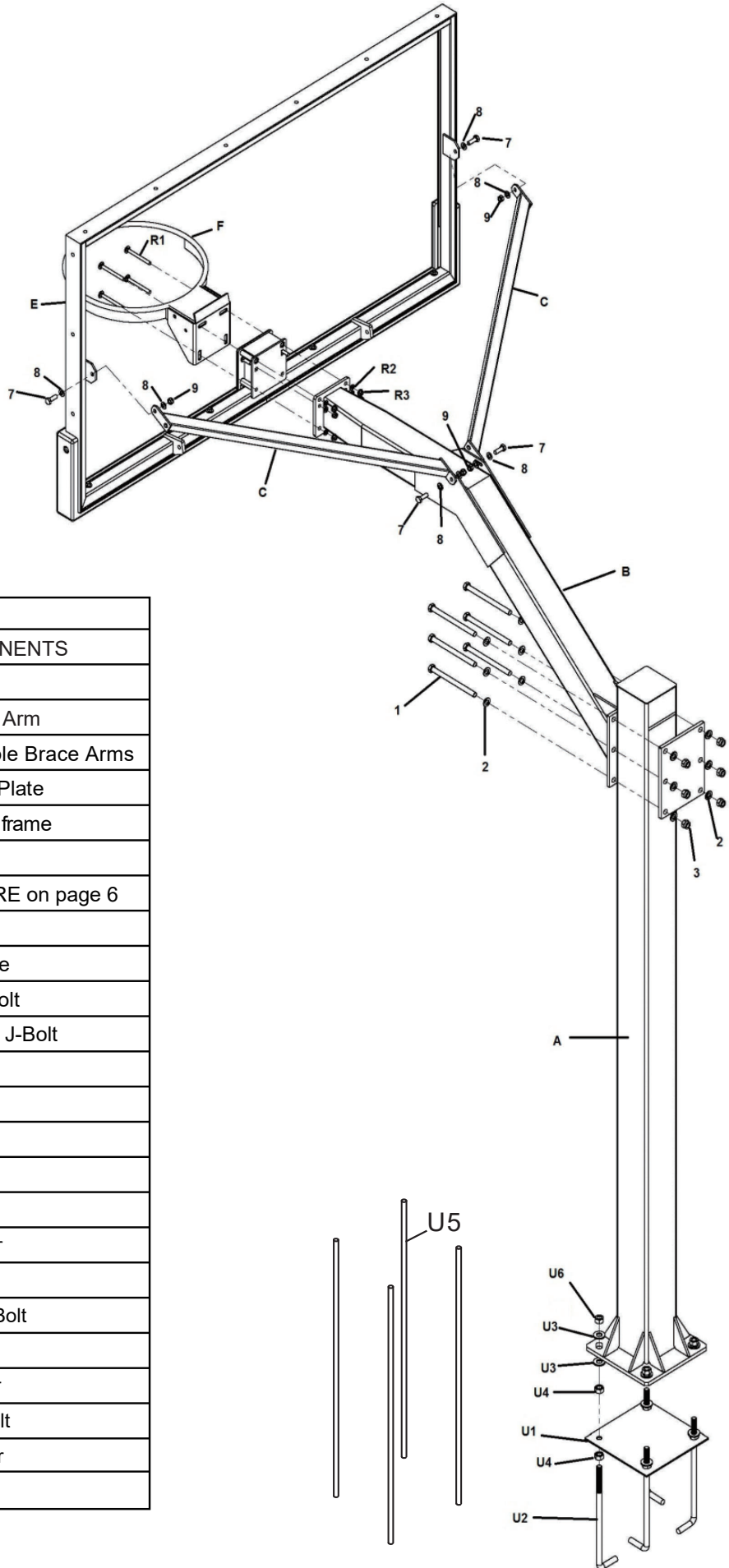

ITEM	QTY	DESCRIPTION
<b>BASKETBALL SYSTEM COMPONENTS</b>		
A	1	Main Post
B	1	Main Extension Arm
C	2	Upper Adjustable Brace Arms
D	1	Extension Arm Plate
E	1	Backboard with frame
F	1	Rim
		RIM HARDWARE on page 6
<b>ANCHOR SYSTEM PARTS</b>		
U1	1	Anchor Template
U2	4	5/8" Anchor J-bolt
U3	8	5/8" Washer for J-Bolt
U4	8	5/8" Hex Nut
U5	4	Anchor Rebar
U6	4	5/8" Lock Nut
<b>HARDWARE LIST</b>		
1	6	5/8" Hex Bolt
2	12	5/8" Flat Washer
3	6	5/8" Lock Nut
4	2	3/8" x 1.5" Hex Bolt
5	2	3/8" Lock Nut
6	2	3/8" Flat Washer
7	4	3/8" x 1" Hex Bolt
8	8	3/8" Flat Washer
9	4	3/8" Lock Nut



**Know what's below.  
Call 811 before you dig.**

One, free easy call gets your utility lines marked  
AND helps protect you from injury and expense

#### Utility Markings

Color	Definition
Red	Electric
Yellow	Gas, Oil, Petroleum
Orange	Communication, Phone, TV
Blue	Portable Water, Irrigation
Green/Brown	Sewer
White	Proposed Dig

#### STEP 1

- Ensure ground is level with playing surface. According to [Figure 1](#), dig a cylindrical hole 16" wide and 48" deep.
- Assemble anchor template assembly according to [Figure 2](#) and [3](#). Attach four 5/8" hex nuts (U) 2-1/4" from top of 5/8" anchor j-bolts (U2). Set anchor template (U1) on bolts (U2). Place four 5/8" hex nuts (U) on top of anchor template (U1). As illustrated turn and position the 5/8" anchor j-bolts (U2) inline with anchor template.
- Pour concrete into the hole 18" from the top. Place four rebars (U5) 8" apart forming a square in the center of hole as illustrated in [Figure 1](#).
- Finish pouring concrete into hole. Release any air pockets in concrete.

FIGURE 2:  
ANCHOR  
SYSTEM

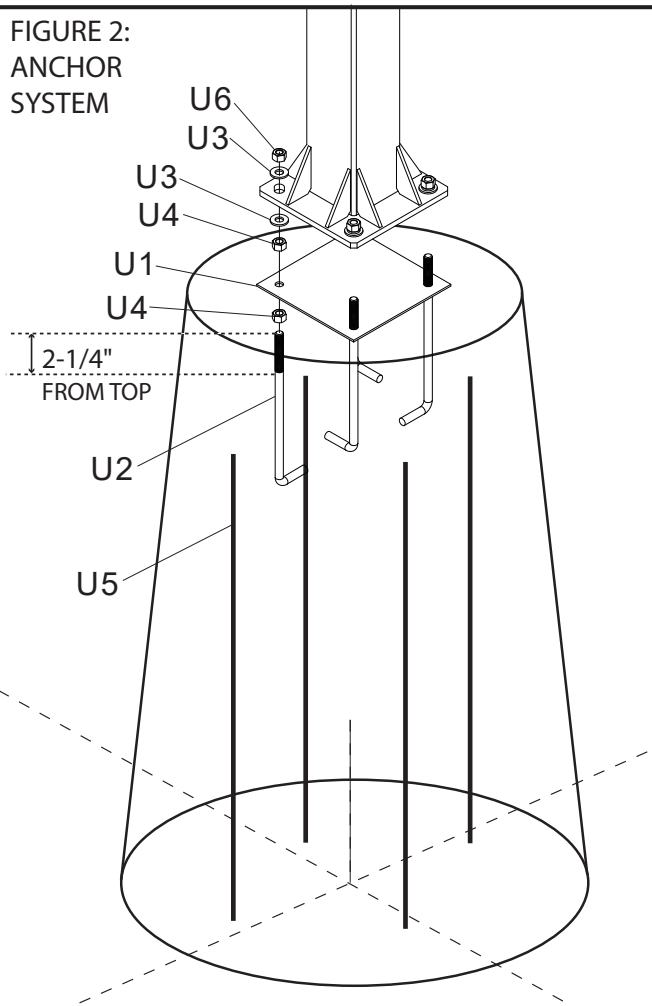
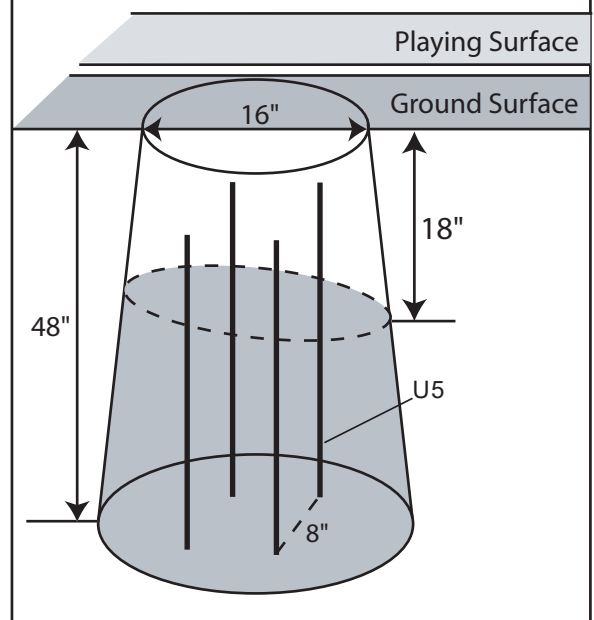
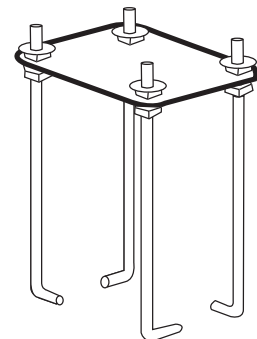

FIGURE 1: CONCRETE FOOTING



- Drop anchor template assembly ([Figure 3](#)) into the center of the wet concrete until the template (U1) is flush with the cement. Level the template and make sure it's parallel with playing surface. Add four 5/8" flat washers (U3). Clean off any excess wet cement from the anchor template.
- Check leveling of mounting plate several times while concrete is curing. Front of mounting plate must be parallel with playing surface.
- Let concrete cure a minimum of 72 hours before continuing to install your basketball system. Allow additional time for cold, wet or humid weather.

FIGURE 3:  
ANCHOR  
TEMPLATE  
ASSEMBLY



**STEP 2**

- A. Position the Main Extension Arm (B) to the 10' Line on Main post (A) as shown in Figure 4
- B. Connect Main Extension Arm (B) to Main Post (A) with one Extension Arm Plate (D), using six 5/8" Hex Bolts (1), twelve 5/8" Flat Washer (2), six Lock nuts (3). See Figure 5

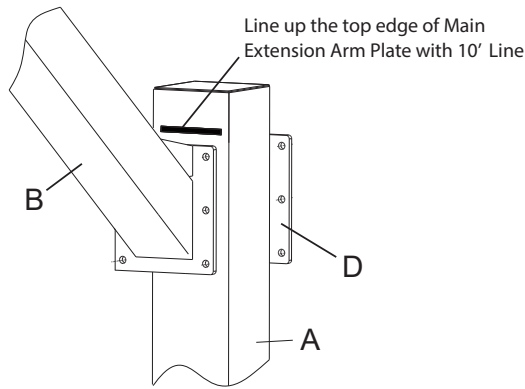

FIGURE 4

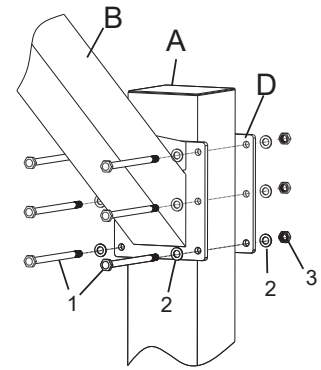

FIGURE 5

**STEP 3**

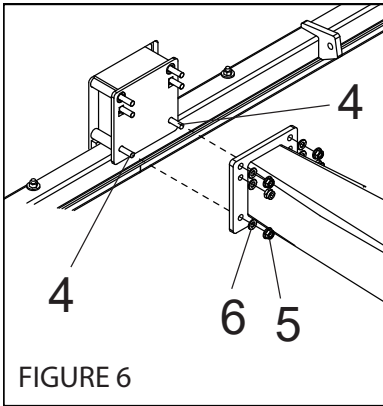

FIGURE 6

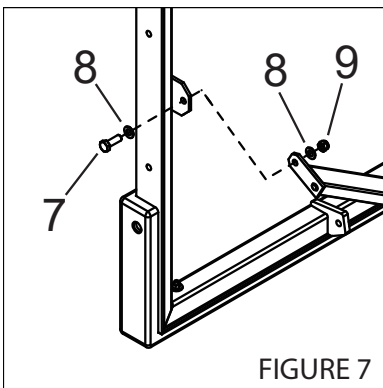

FIGURE 7

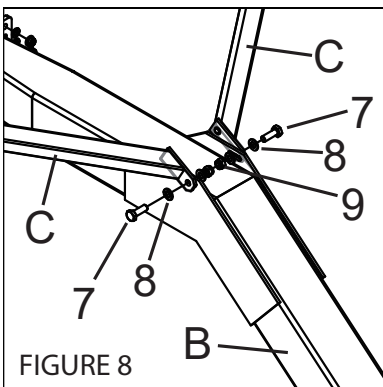

FIGURE 8

- A. Attach backboard frame to Main Extension arm using two 3/8" x 1.5" Hex Bolts (4), two 3/8" flat washers (6) and two 3/8" lock nuts (5) according to Figure 6.

Note: Some backboards may not be compatible for this step. Attach backboard to extension and rim with rim hardware if needed.

- B. Follow Figure 7 and attach backboard frame to upper adjustable brace arms using two 3/8" x 1" Hex Bolts (7), four 3/8" flat washers (8) and two 3/8" lock nuts (9).

- C. Tighten the upper adjustable brace arms (C) to Main Extension Arm (B) by using two 3/8" x 1.5" Hex Bolts (#7), four 3/8" Flat Washers (#8) and two 3/8" Lock Nuts (#9) according to Figure 8.

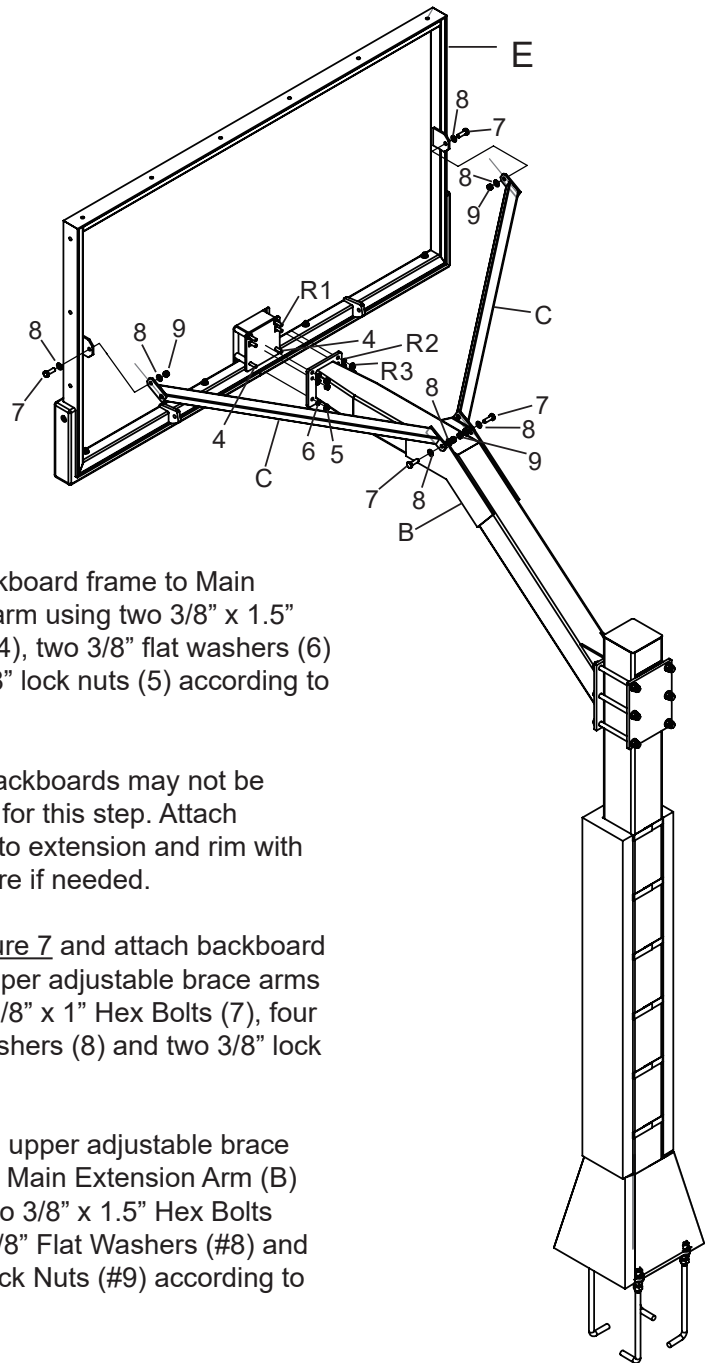

## STEP 4

- A. Remove the screws on Rim spring box cover, open the Spring box.  
*(Rim Spring Box cover may not be factory-assembled.)*

Slide 4 Carriage bolts M10x 4.33" (R1-rim hardware kit) thru Rim plate, Spacers and Backboard, secure with 4 Flat washers M10 (R2-Rim hardware kit ) and 4 Flange nuts M10 (R3-Rim hardware kit ) from the backside of Backboard.

- B. Mount the rim to the Mounting bracket on Backboard (E) using the hardware supplied in the rim box

- C. Re-attach Spring box cover to the Rim with removed screws.

*NOTE: Use a level to make sure rim is level side to side before tightening nuts.*

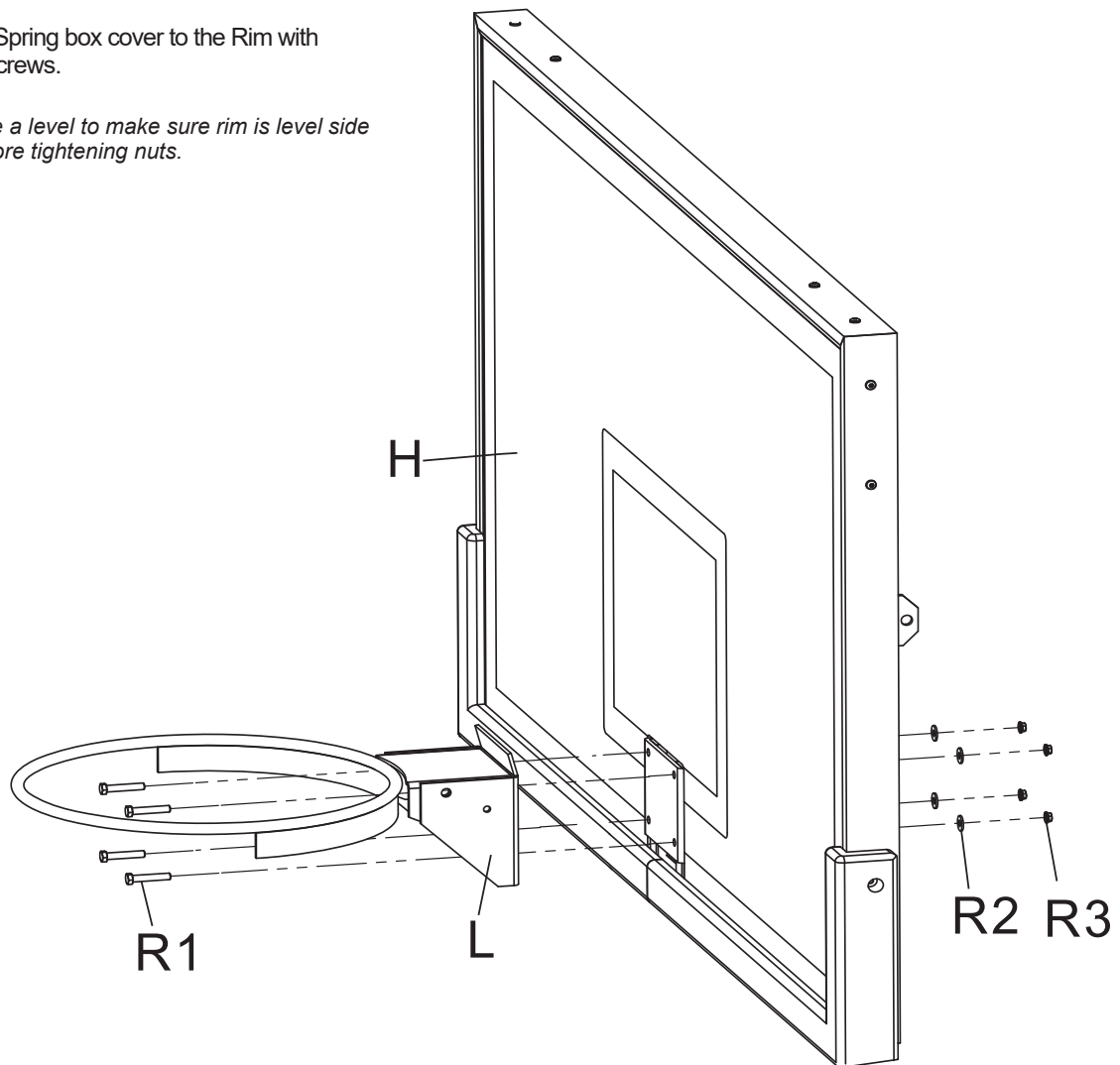

### RIM HARDWARE

R1	4 PCS	Carriage bolt M10X4.33"
R2	4 PCS	Flat Washer M10
R3	4 PCS	Flange Nut M10